

Crane Scale

CASTON II

OWNER'S MANUAL



9007-CT2-0033-2

2004, 5

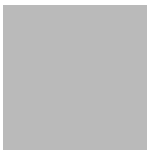

CONTENTS

PRECAUTIONS	4
PREFACE	6
NAMES AND FUNCTIONS	6
OPERATIONS	9
1. INSTALLATION	9
2. BATTERY COUPLING	9
3. OPERATION	10
4. HOLD FUNCTION	10
PRODUCT SIZE	11
SPECIFICATIONS	12

PRECAUTIONS

To installate, safety pin in hook should be fixed to prevent dropping out from lift eye bolt.

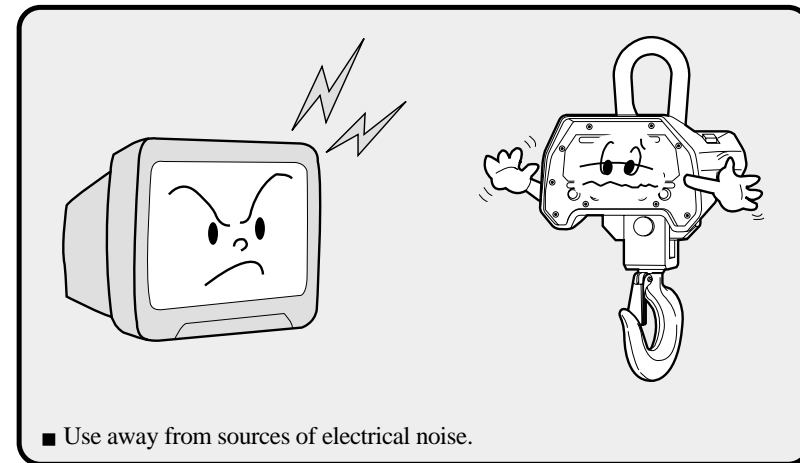
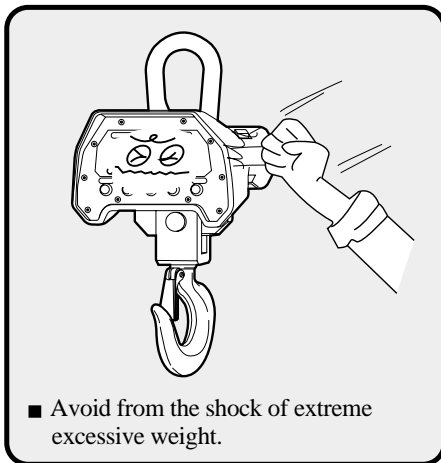
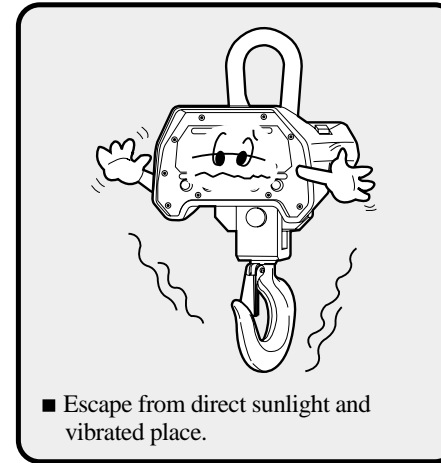
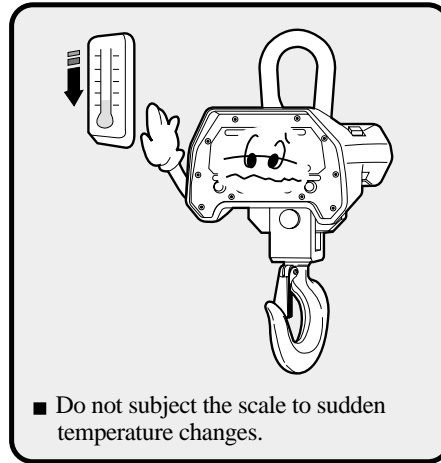
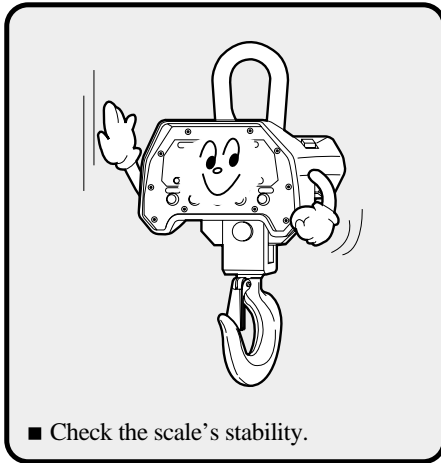

PREFACE

Thank you for purchasing our CAS CASTON II. These series have been designed with CAS reliability, under rigid quality control and with outstanding performance. Your specialty departments can enjoy these high quality reliable CAS products. We believe that your needs will be satisfied and you will have proper reliability. This manual will help you with proper operation and care of the CASTON II. Please keep it handy for future reference.

NAMES AND FUNCTIONS

OVERALL VIEW

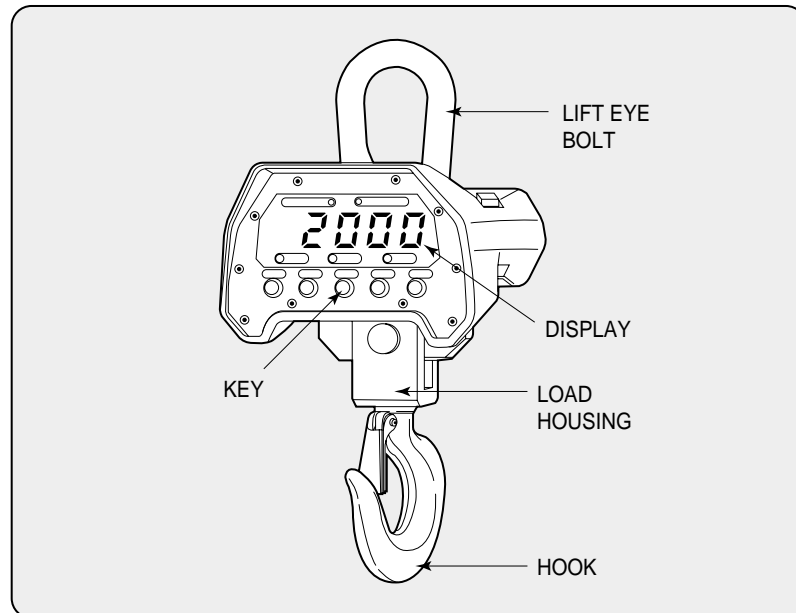

DISPLAY & KEYBOARD

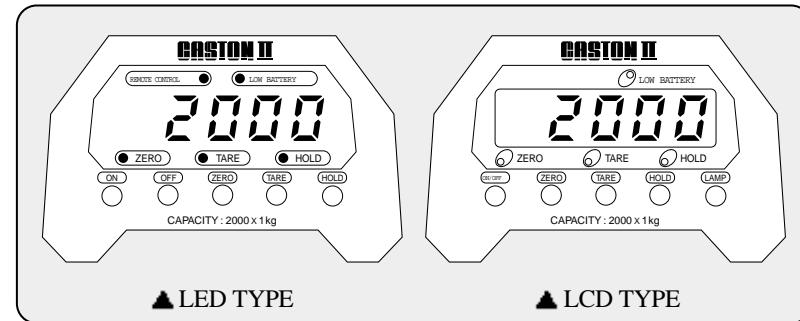

■ DISPLAY

WEIGHING LAMP: This lamp used for reading weight.

ZERO LAMP: Used for checking stability.

TARE LAMP: Used for entering tare weight and it is on only while tare weight has entered.





HOLD LAMP: It is ON while HOLD key is pressed.

BATTERY: It informs battery charging time.

■ KEY FUNCTION (LED TYPE)

KEYS	FUNCTIONS
ON	Used for turning on display.
OFF	Used for turning off display.
ZERO	Weight display returns to zero.
TARE	Tare value setting.
HOLD	Used to weigh moving thing. (Manual / Automatic)

■ KEY FUNCTION (LCD TYPE)

KEYS	FUNCTIONS
	Used for ON or OFF the power.
	Brings the display to "0" while drifted.
	This key is used to preset tare weight and subtract or clear the tare weight.
	Used to weigh moving things. (Manual / Automatic)
	This back light used as a light while the scale used in dark area.

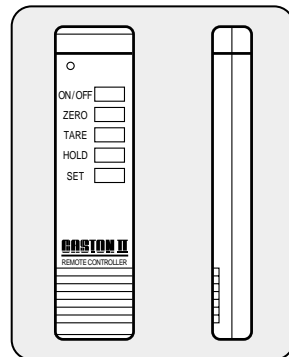

Remote Control (LED TYPE)

- ON/OFF: Button to save battery life while pause in operating condition.
 - ZERO: Button to correct zero value.
 - TARE: Used to tare value memorizing.
 - HOLD: Used to weigh moving thing.
- ▶ Notice: Power ON/OFF function of the scale itself: use only main ON/OFF switch.

OPERATIONS

1. INSTALLATION

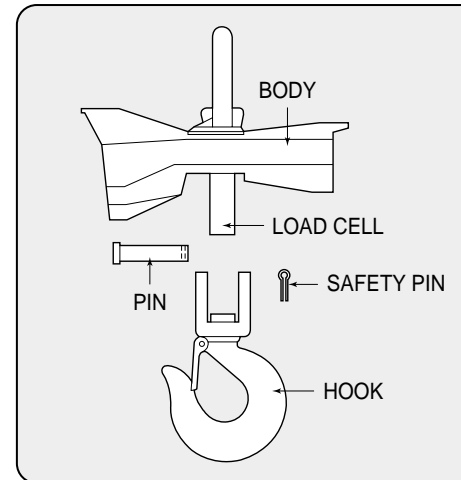

- Tighten the Load Cell and the Hook and then insert pin into the hole in Hook.
- Fix the pin with a safety pin. Fold the safety pin to tighten it.

2. BATTERY COUPLING

- Couple connector in main body with connector in battery portion.
- Insert battery portion to the main body and turn fixing bolt to the right to fix.

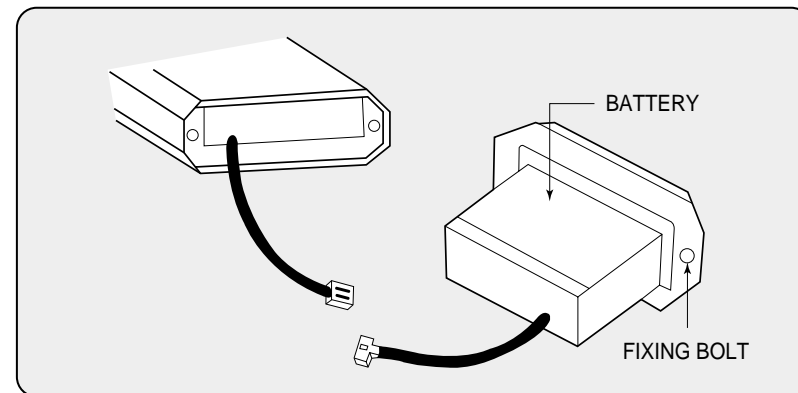

3. OPERATION

- Check self test of display by pressing ON switch. It will turn to initial display condition. (ON/OFF button wouldn't work while the scale's power is in OFF.)
- The ON/OFF key of remote control: Turn on and off of display only. (LED TYPE)
- BATTERY: Return to normal mode from battery save mode. Press any key on the scale or ON/OFF button of remote control. (LED TYPE)

4. HOLD FUNCTION

Auto Hold Function

- Press HOLD key when the display shows “0”.
- “Auto Hold on” will displayed and HOLD lamp will be on.
- In case of weighing moving thing, “Hold” will appear after the weight is stable. After that, mean value will be displayed.
- Displayed value will remove when you remove things from the hook. And HOLD lamp still is on. In case of weighing moving things. “Hold” will appear again after the weight is stable.
- When you need to turn to normal mode from the automatic hold mode, press HOLD key when the display shows “0”.
A message that “Auto Hold on” will be displayed, at the time HOLD lamp is off.

Manual Hold Function

- Press HOLD key after weighing moving things. “HOLD” message will appear and little while after mean value would be displayed.
- To remove manual hold made, automatically return to the normal mode by removal things from the hook.

USAGE OF BATTERY CHARGER

- Check the voltage of battery charger before use. (It is fixed to 220V before delivered.)
- Insert charger into the power source and connect the discharged battery to the connector.
- Turn on the switch on the battery charger, charging will start.
- You could check charging condition with LED, LCD in CASTON II. When the LED, LCD lamp is on, it means charging is fully made.
- Estimated time for the charging is 8 hours. (Charging time can be varied according to the battery condition.)

PRODUCT SIZE

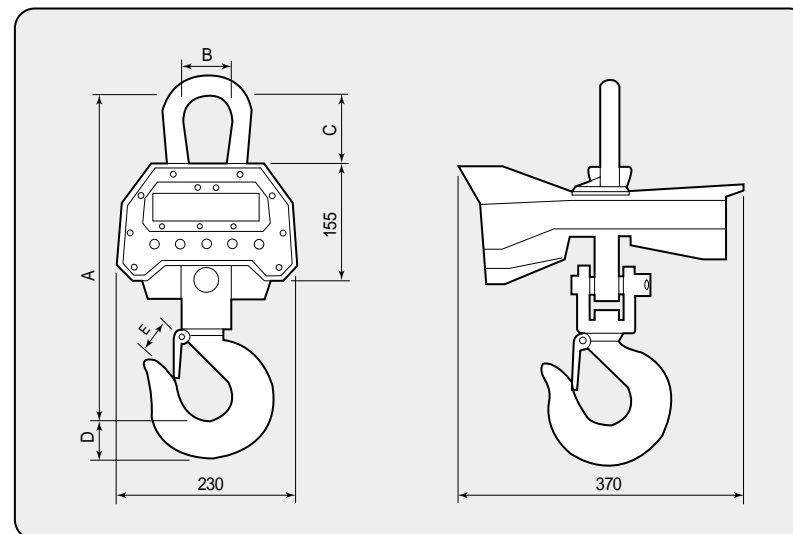

MODEL	CAPACITY	GRADUATION	A	B	C	D	E	WEIGHT
0.5THB	500kg	200g	350	57.1	77.7	30	26	15kg
	1000LB	0.5LB						
1THB	1TON	500g	350	57.1	77.7	30	26	15kg
	2000LB	1LB						
2THB	2TON	1kg	430	57.1	77.7	44.5	34	17kg
	4000LB	2LB						
3THB	3TON	2kg	430	57.1	77.7	44.5	34	17kg
5THB	5TON	2kg	474	57.1	77.7	44.5	40	20kg
	10000LB	5LB						

SPECIFICATIONS

MODEL	CASTON II	
	LED TYPE	LCD TYPE
MAX. TARE WEIGHT	FULL TARE	
DISPLAY	LED(1.2 inch)	LCD(1 inch)
TEMPERATURE RANGE	-10°C ~ +40°C	
POWER SOURCE	6V	
POWER CONSUMPTION	1W	
DISPLAY LAMP	ZERO, TARE, HOLD, BATTERY LAMP	

REMOTE CONTROL (LED TYPE)	
AVAILABLE DISTANCE	6m ~ 9m
AVAILABLE ANGLE	60°
POWER	3V(1.5V AMM × 2)

► Notice: Specifications are subject to change for improvement without notice.

MEMO



MEMO

